

切り口の作図の大前提

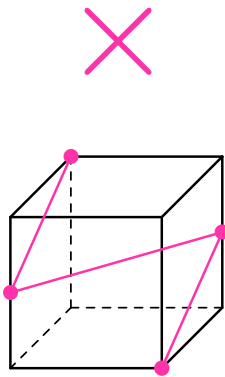

切り口を表す線は、必ずはじめと最後がつながった輪になります。

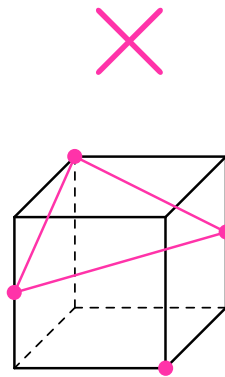

切り口を表す線は、立方体の中ではなく必ず立方体の表面にできます (※)。

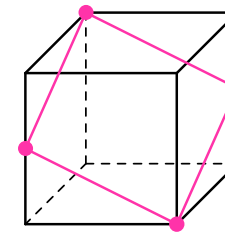

切り口の線は

- ・輪になる
- ・表面にできる

※このことより、立方体の表面は6面ですから、立方体を1回切ったときの切り口は、最高6角形までしかできないことが分かります。また、立方体を2回以上切ると、切り口を表す線は立方体の内部にもできます。

切り口の作図のポイント①

「同一平面上の2点を結ぶ」

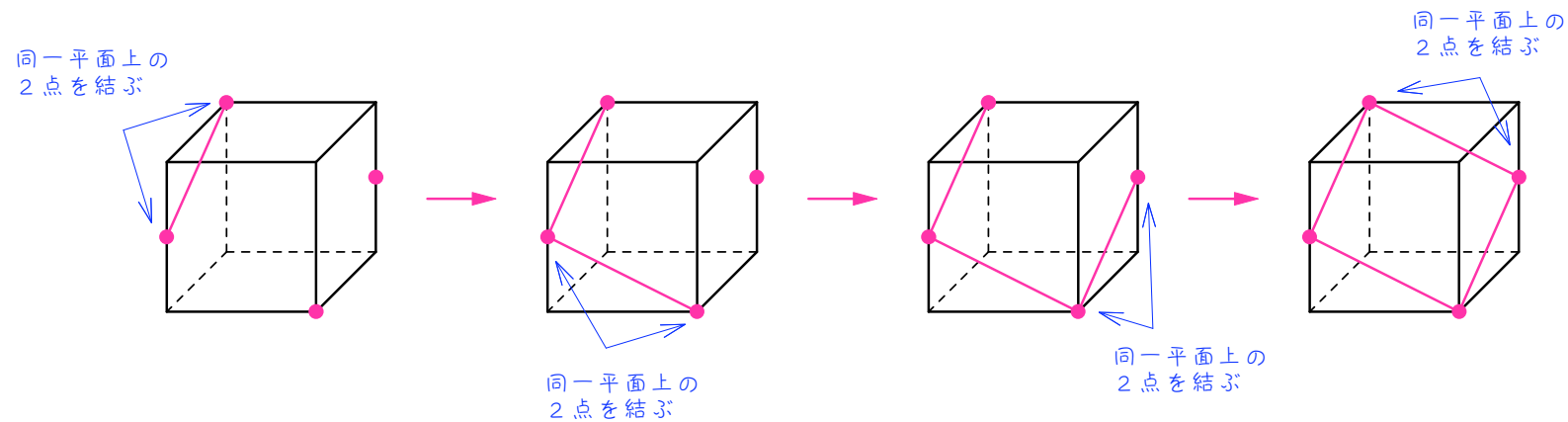



立方体を切断すると、切り口は必ず三角形、四角形、五角形、六角形のいずれかになり、切り口の多角形の辺は、必ず立方体の面の上にあります。例にならって同じ面にある●を結んで立方体の切り口を作図しなさい。

例

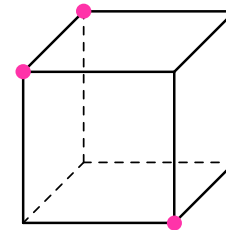
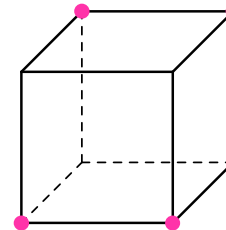
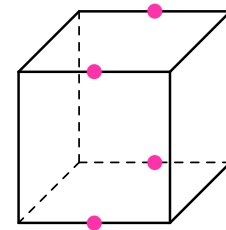
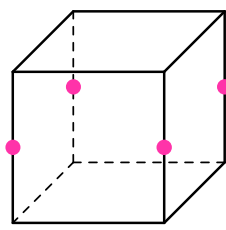
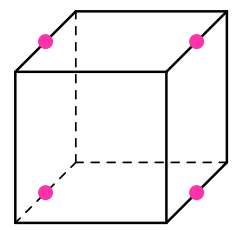
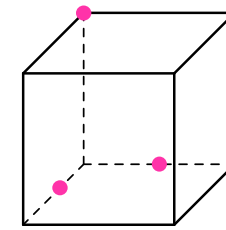
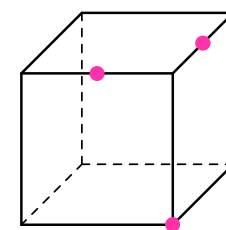
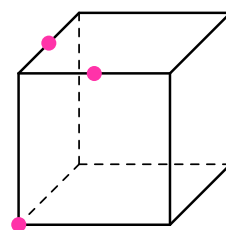
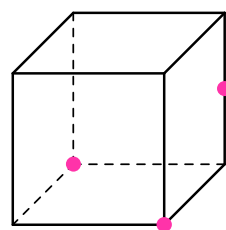
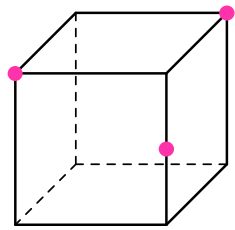
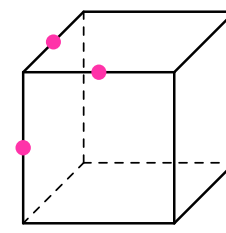
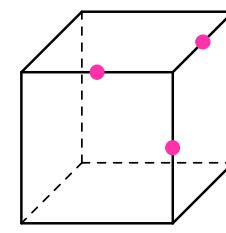
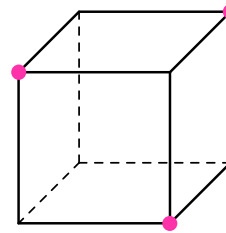
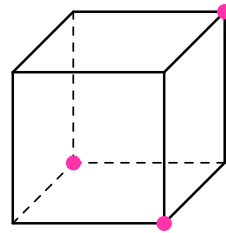
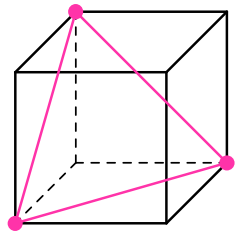

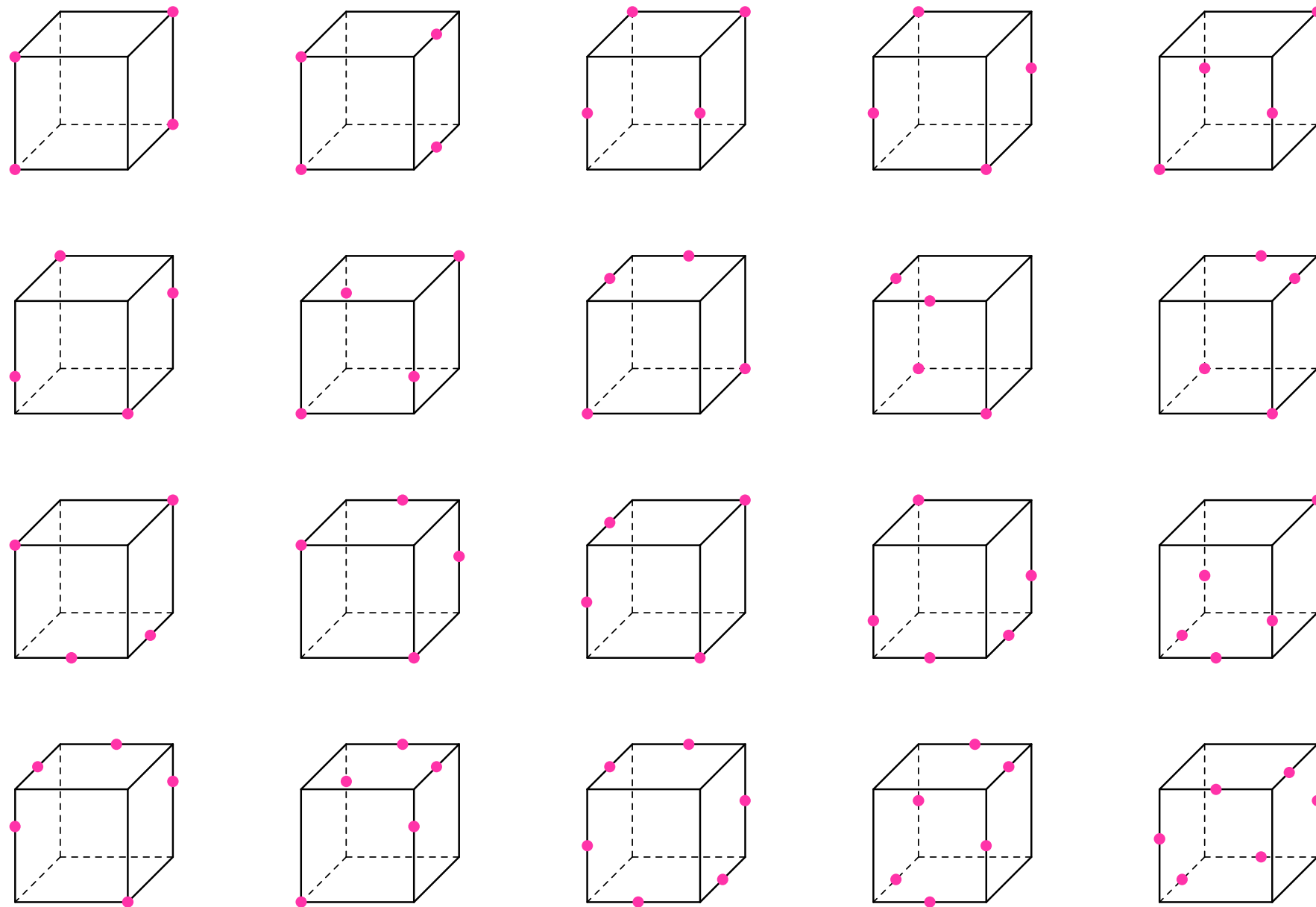

切り口の作図の大前提

「切り口(平面)は3点で決まる」

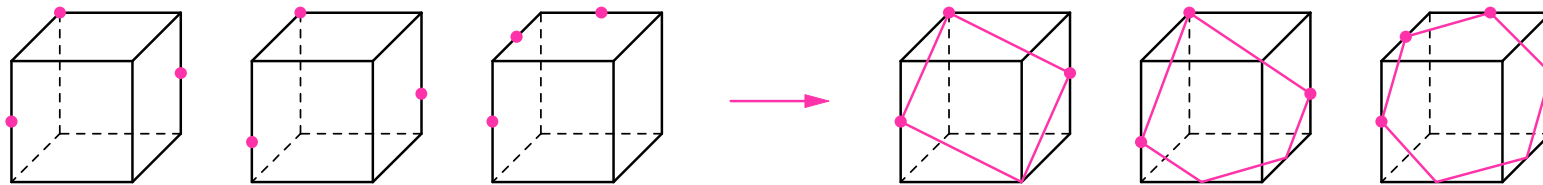

問題には3点しか示されていないくても、

3点を通る切り口は、四角形や五角形や六角形になる場合があります。

3点から四角形や五角形や六角形を作図するには、あと2つ、ポイントが必要です。

※カメラの三脚が3本足なのは、3本足だと平面がただ1つ決まり、カメラが安定するからです。4本足だと、グラグラします。

切り口の作図のポイント②

「平行な面の切り口は平行」

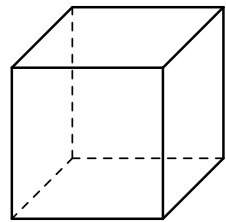

立方体は、上下の面、
左右の面、前後の面
が平行。

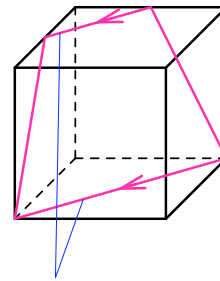

上下の面が平行
だから平行

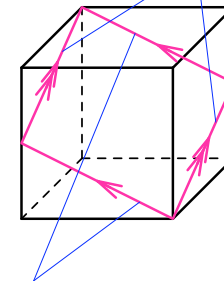

前後の面が平行
だから平行

左右の面が平行
だから平行

2

立方体を切断してできる切り口の多角形の辺のうち、平行な面にある辺は必ず平行になります。例にならって、切り口の平行な辺に印をつけなさい。

例

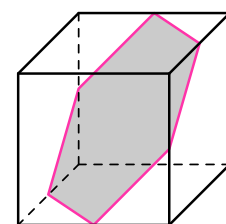
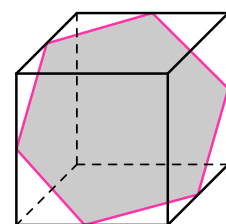
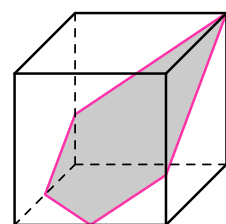
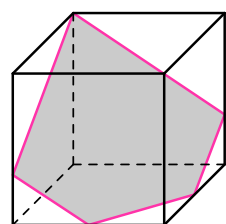
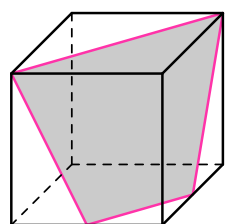
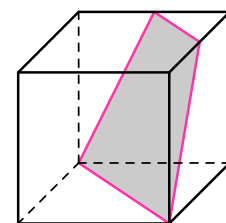
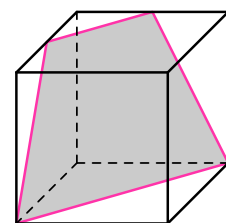
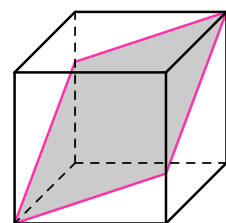
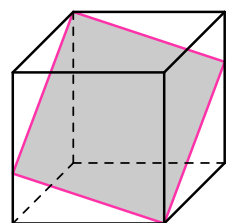
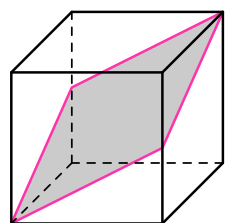
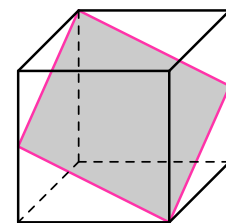
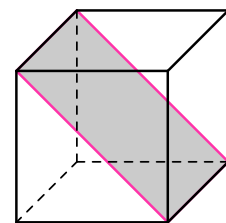
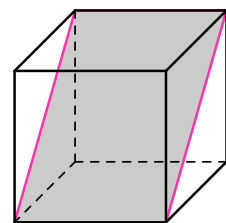
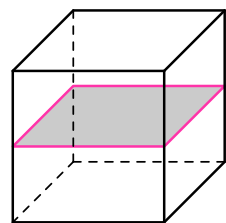
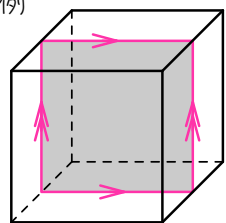

3

次の図は立方体を斜めに切ったものです。□にあてはまる数を求めなさい。
 (切り口の辺のうち、平行な面にある辺は平行であることを利用しなさい)

(1)

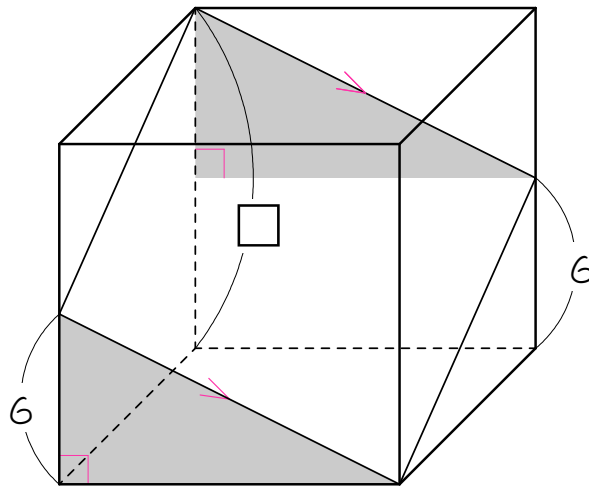

(2)

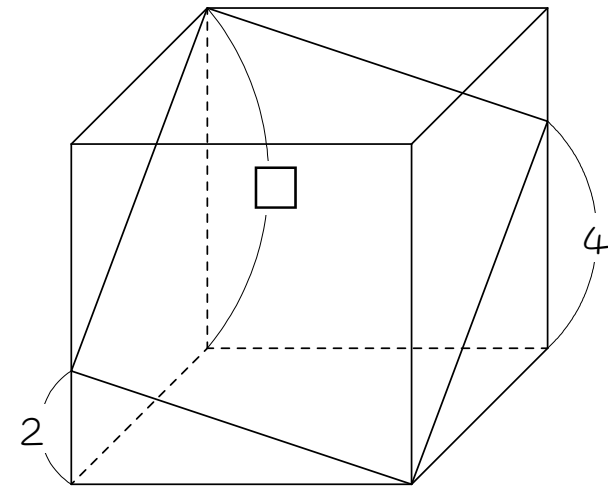

印のついた辺は平行だから、
 色のついた直角三角形は合同。

(3)

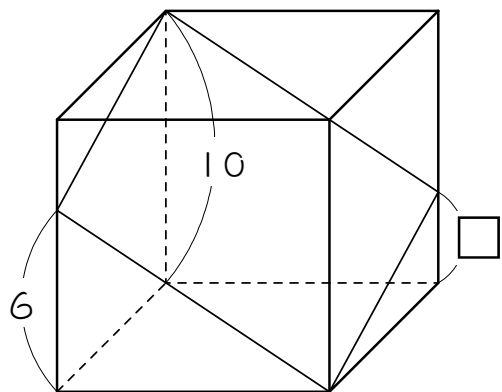

(4)

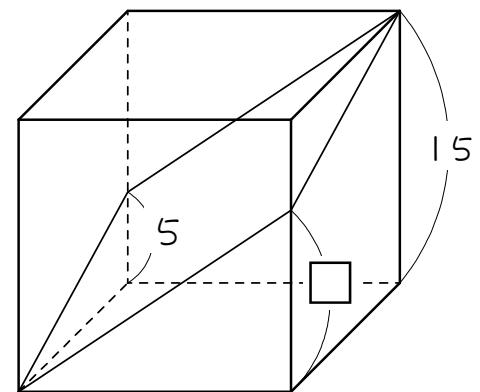

(5)

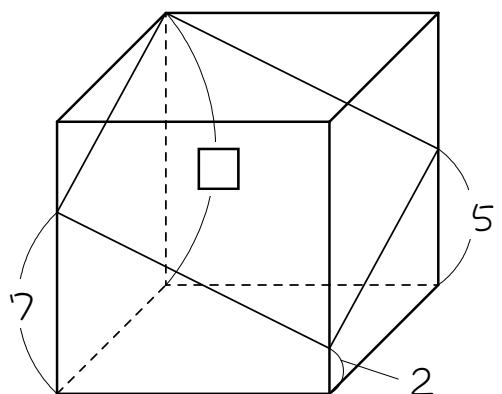

(6)

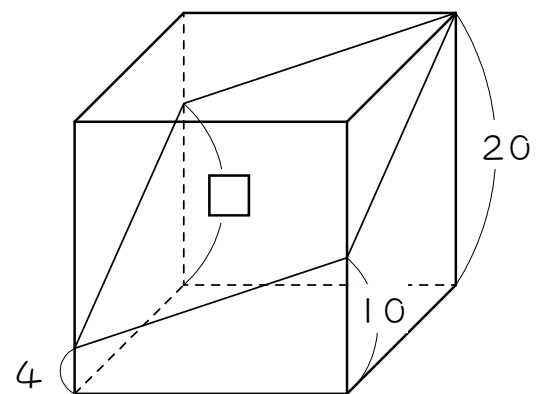

(7)

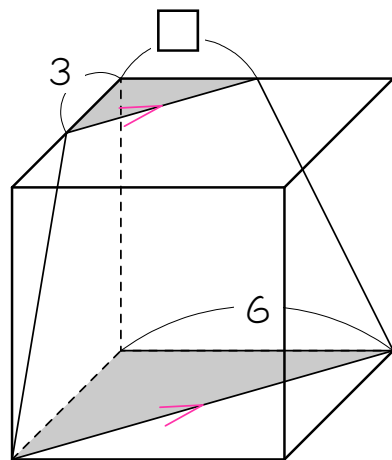

色のついた直角三角形は相似。
(直角二等辺三角形です)

(8)

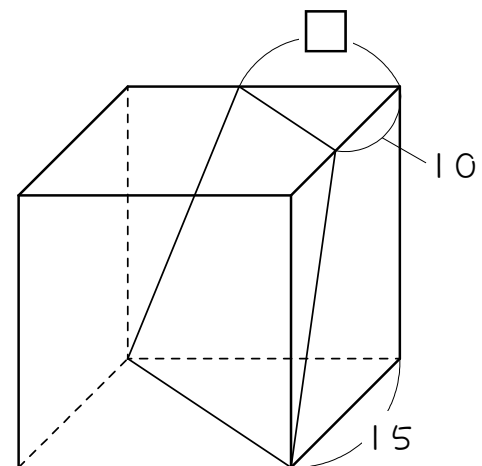

(9)

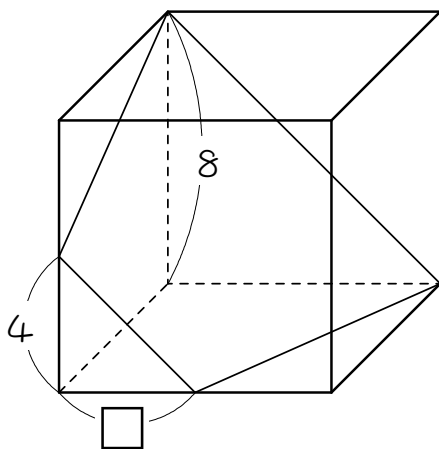

(10)

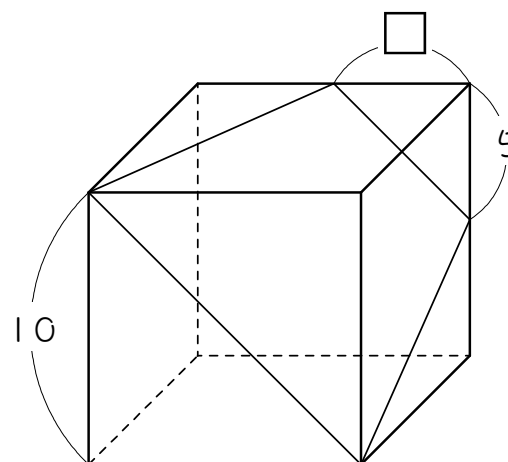

4

例にならって、●を通り、太線に平行な直線をかきなさい。なお、立方体の辺にある印は、各辺の6等分点です。

例

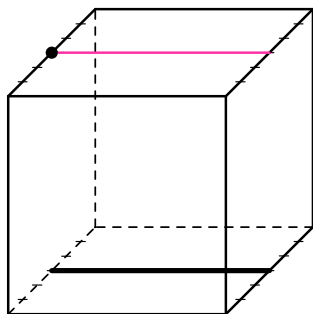

(1)

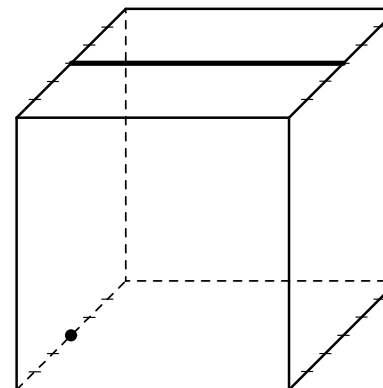

(2)

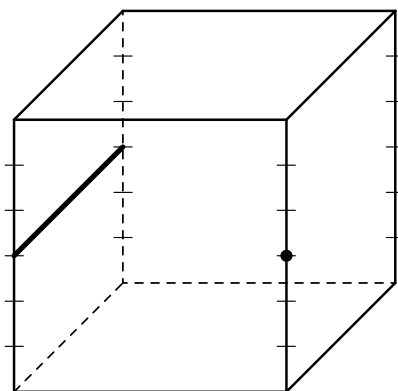

(3)

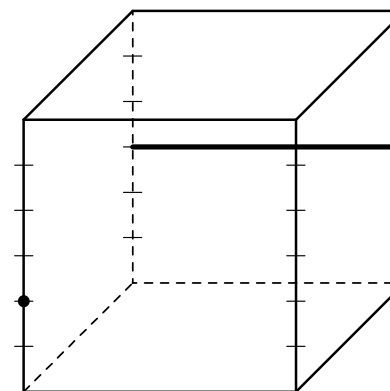

(4)

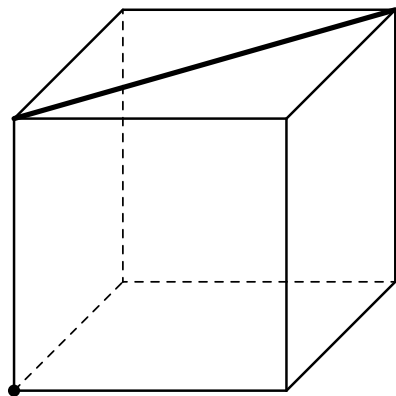

(5)

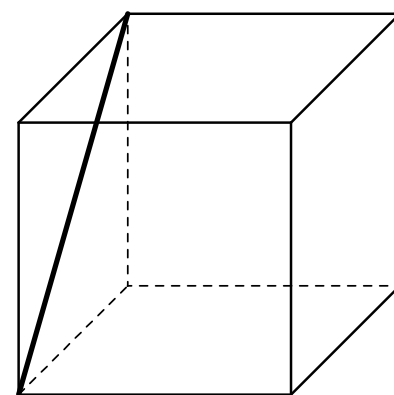

(6)

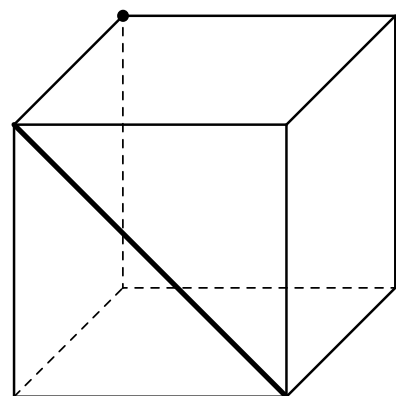

(7)

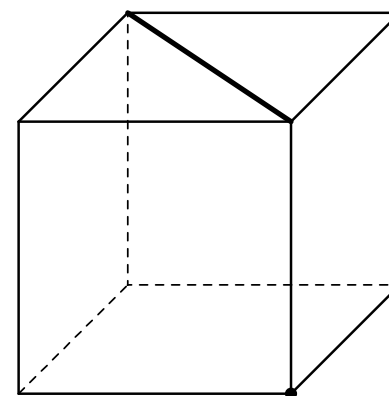

(8)

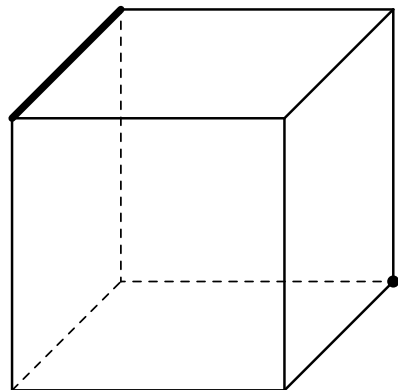

(9)

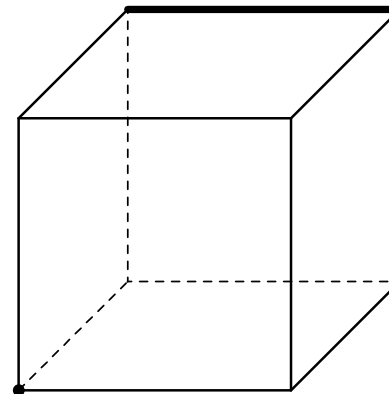

(10)

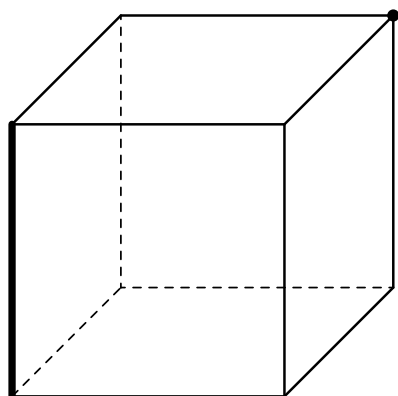

(11)

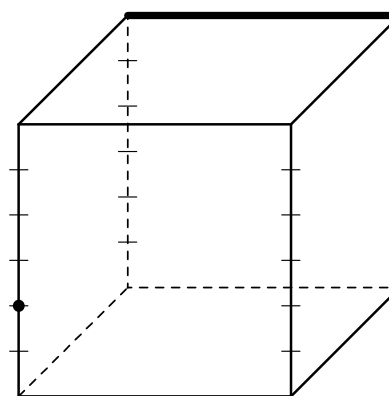

(12)

これと同じ直角三
角形を向かい合う
面にも作ります。

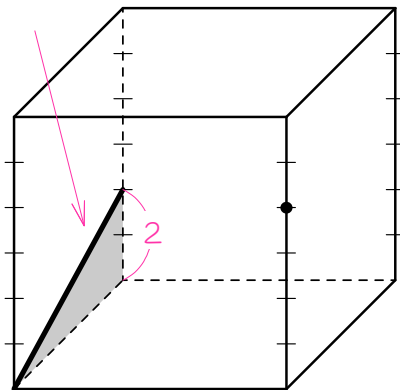

(13)

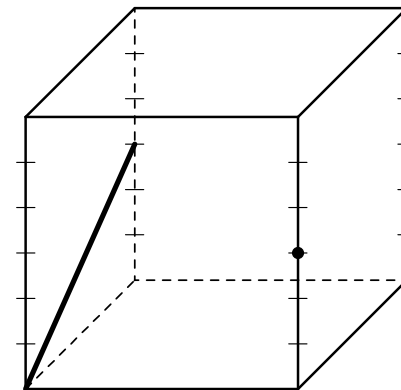

(14)

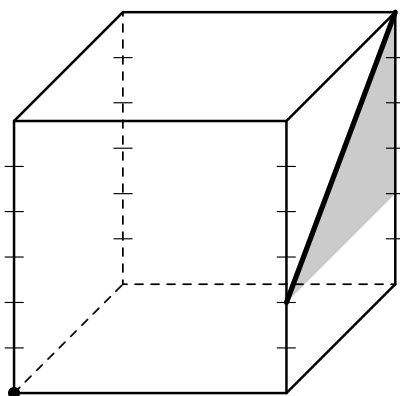

(15)

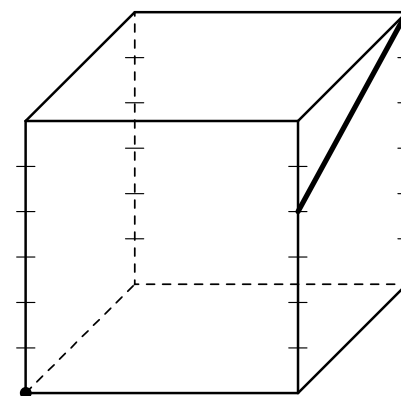

(16)

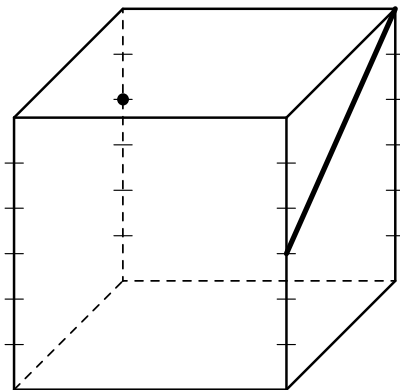

(17)

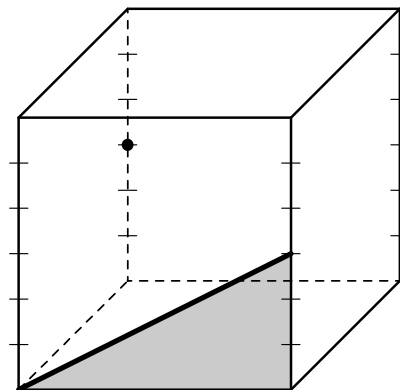

(18)

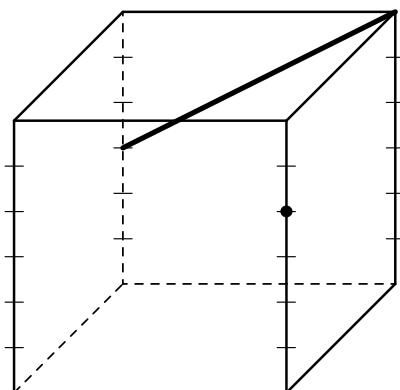

(19)

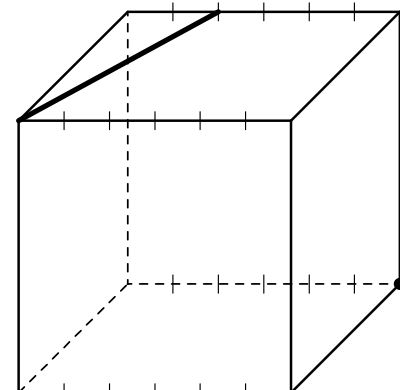

(20) ここが直角二等辺三角形だから、
向かい合う面にも●を通る直角二等辺三角形を作ります。

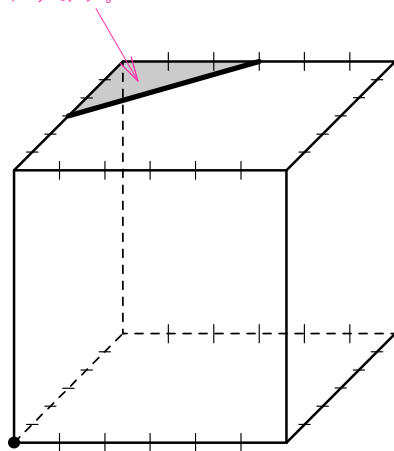

(21)

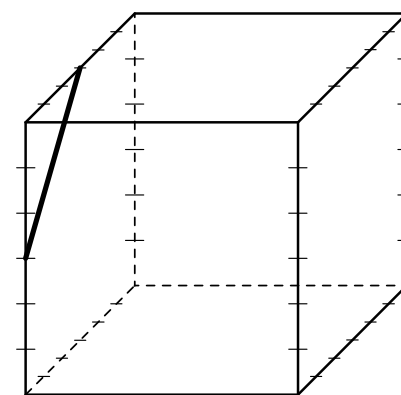

(22)

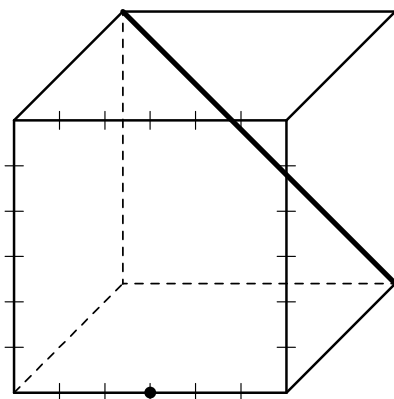

(23)

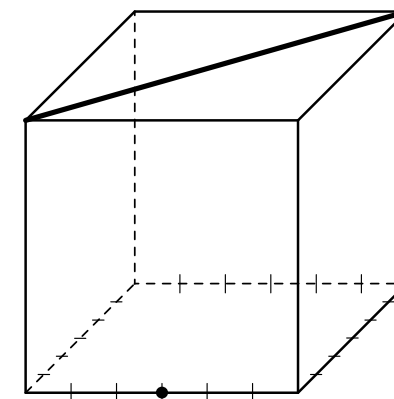

5

立方体を3点P、Q、Rを通る平面で切ったときの切り口を作図しなさい。
 (3点P、Q、Rは立方体の頂点または各辺の中点、3等分点のいずれかです)

(1)

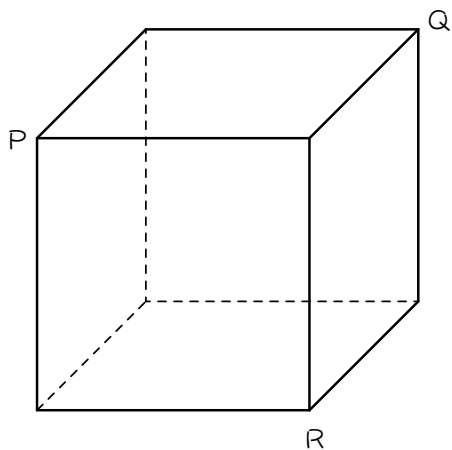

(2)

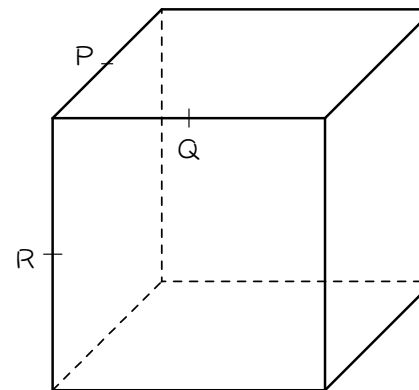

(3)

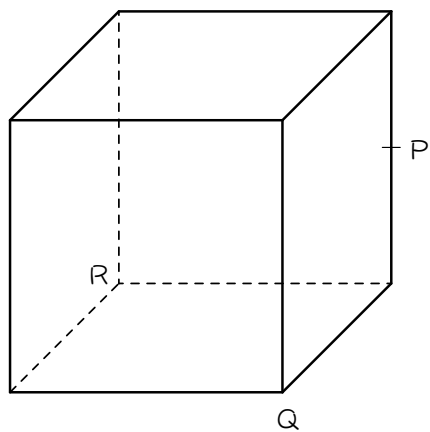

(4)

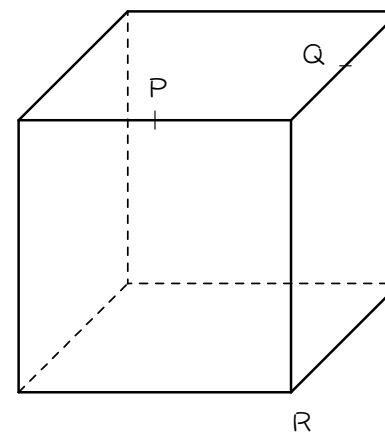

(5)

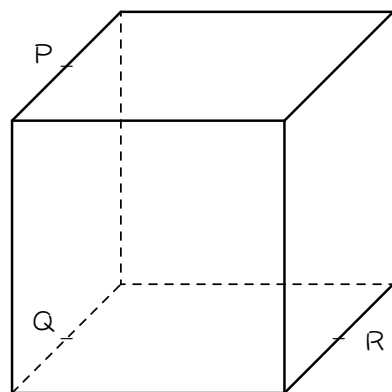

(6)

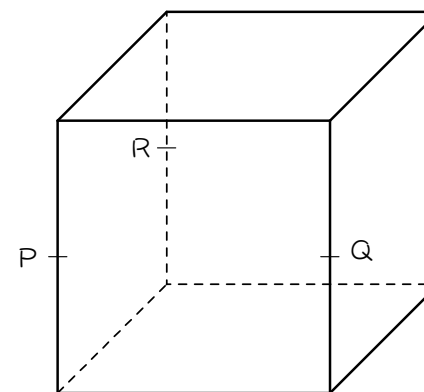

(7)

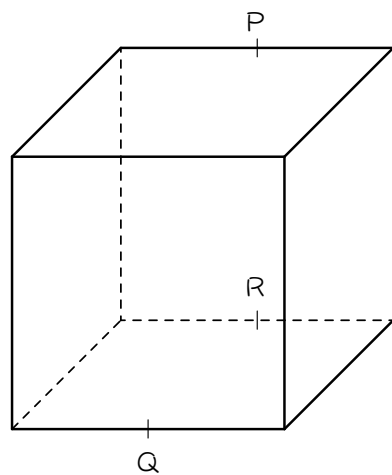

(8)

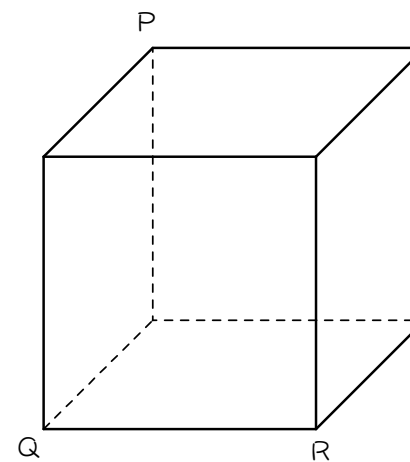

(9)

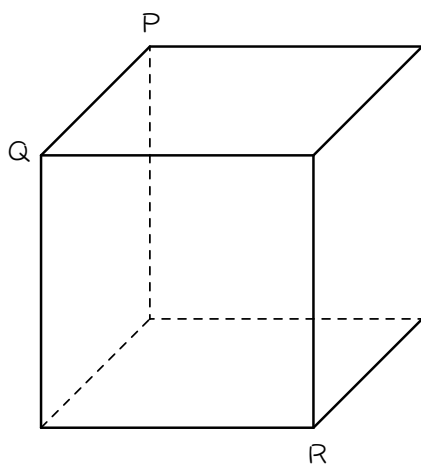

(10)

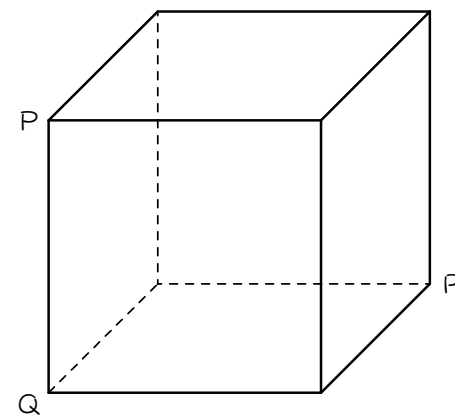

(11)

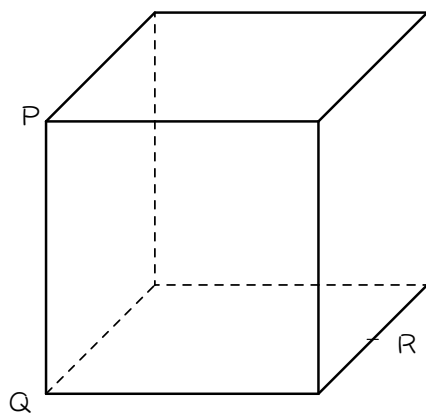

(12)

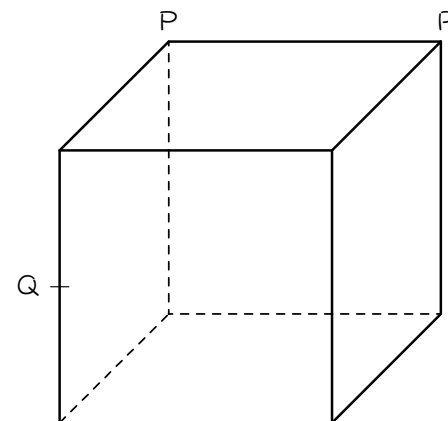

(13)

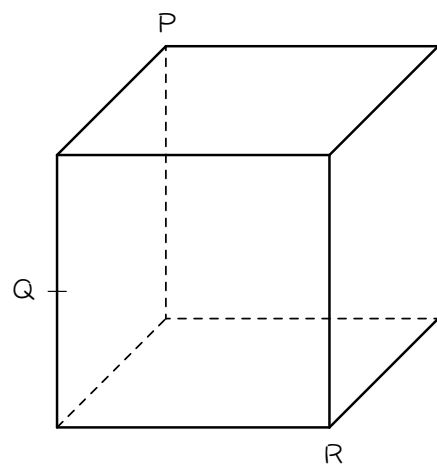

(14)

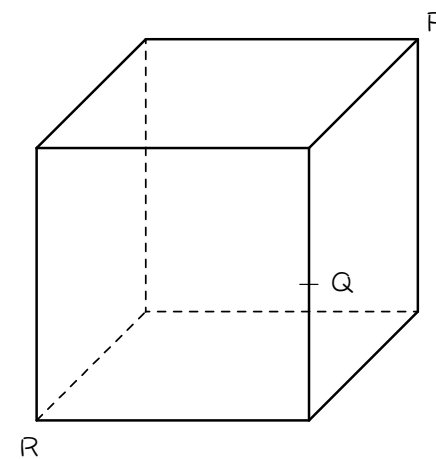

(15)

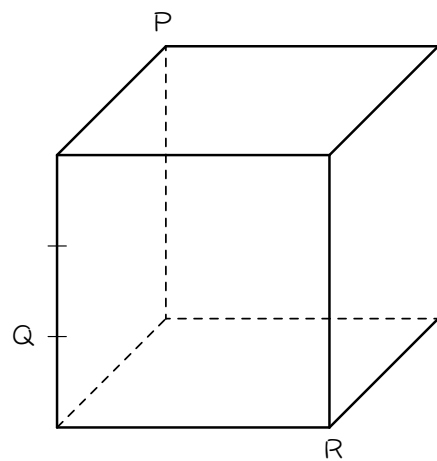

(16)

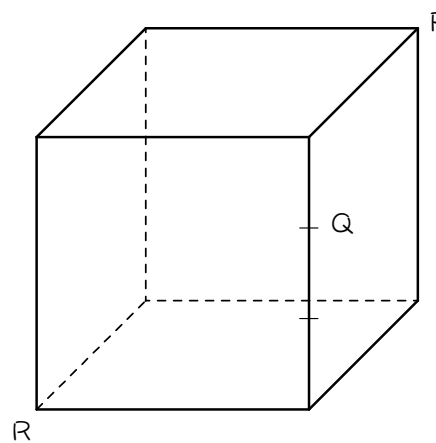

(17)

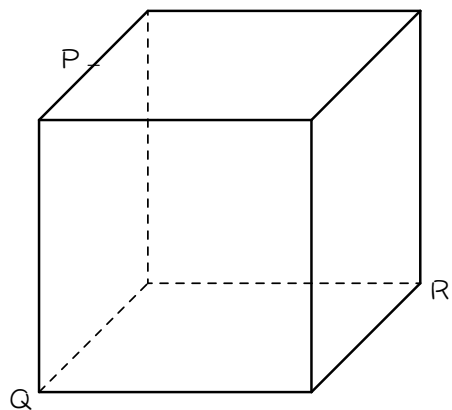

(18)

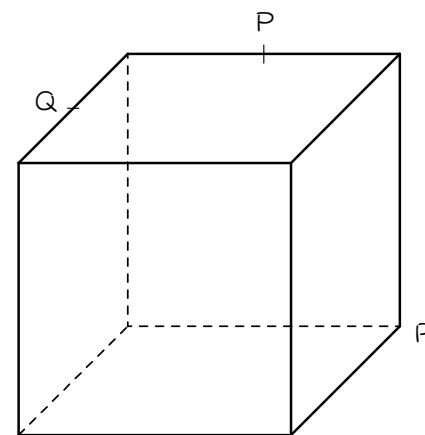

(19)

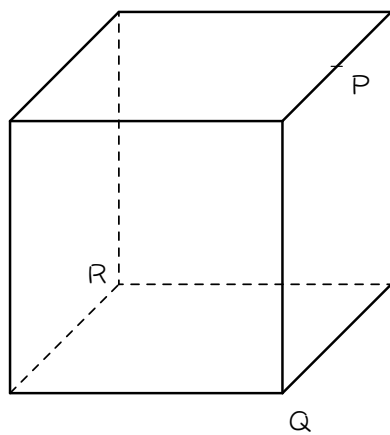

(20)

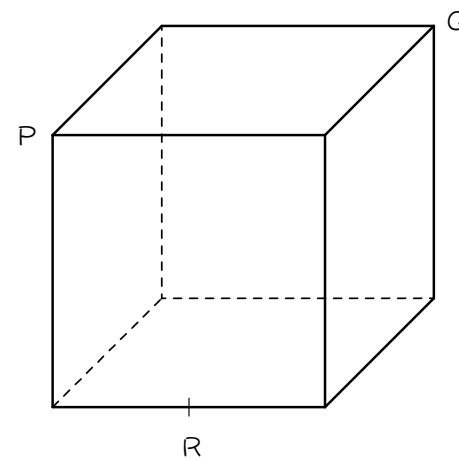

(解答)

1

例

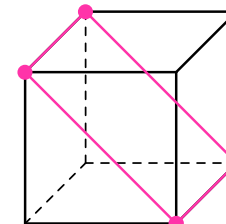
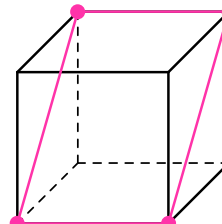
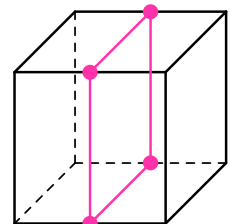
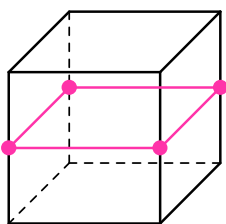
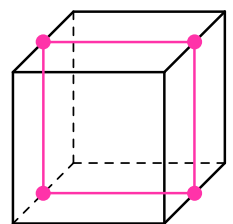
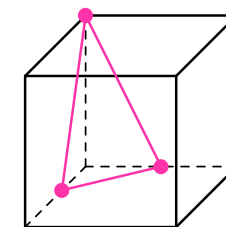
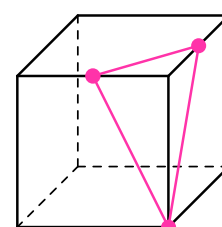
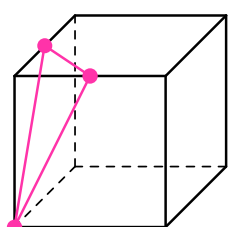
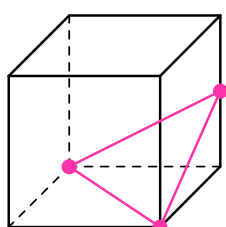
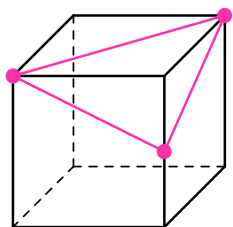
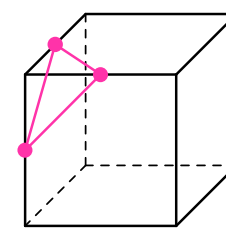
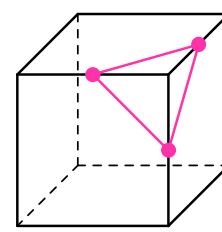
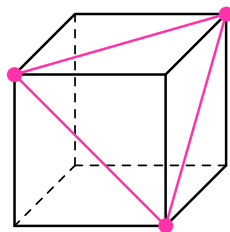
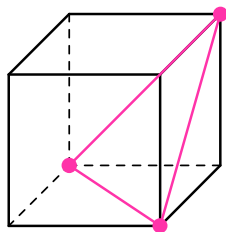
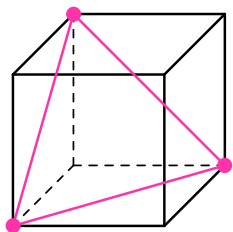

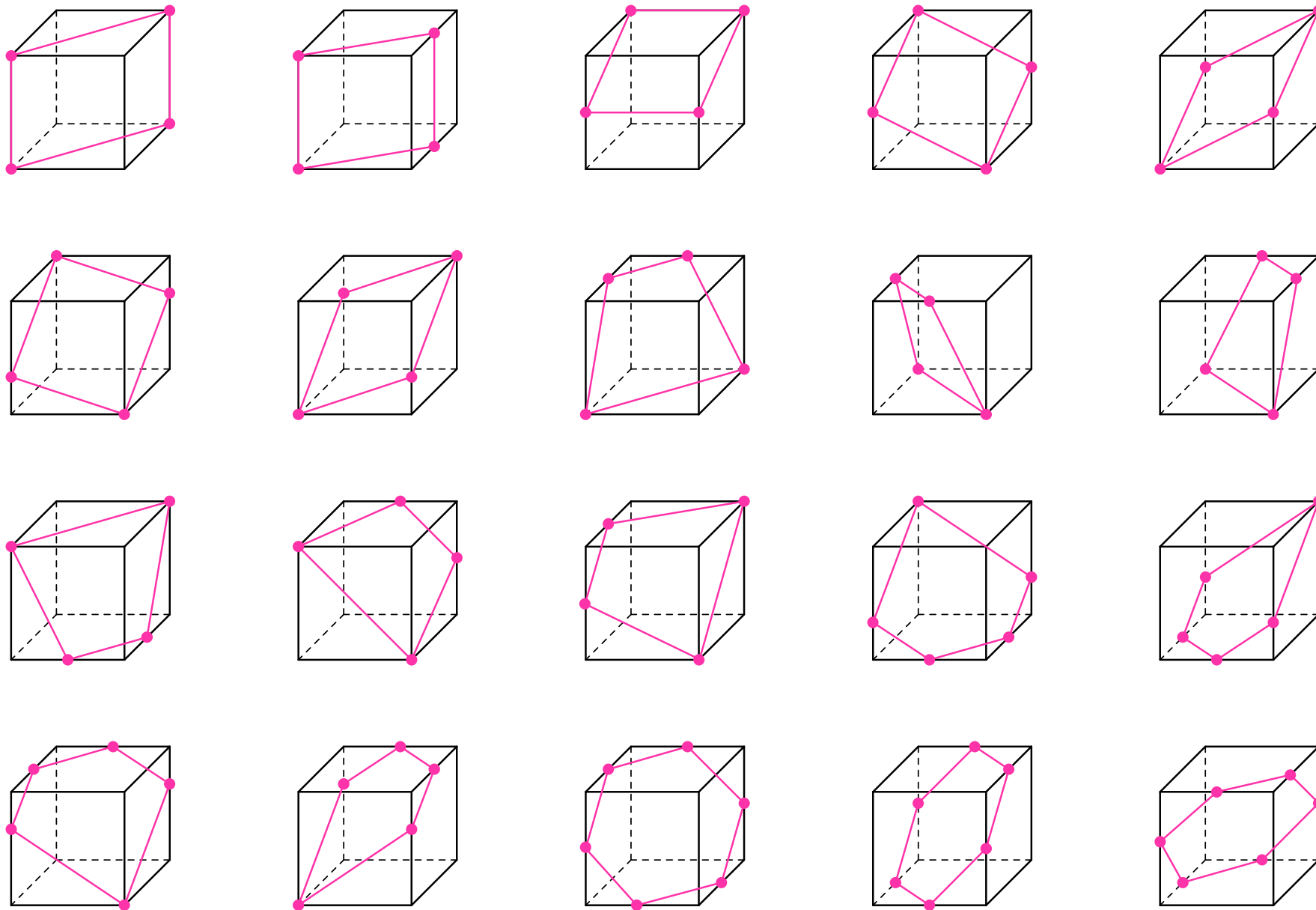

2

例)

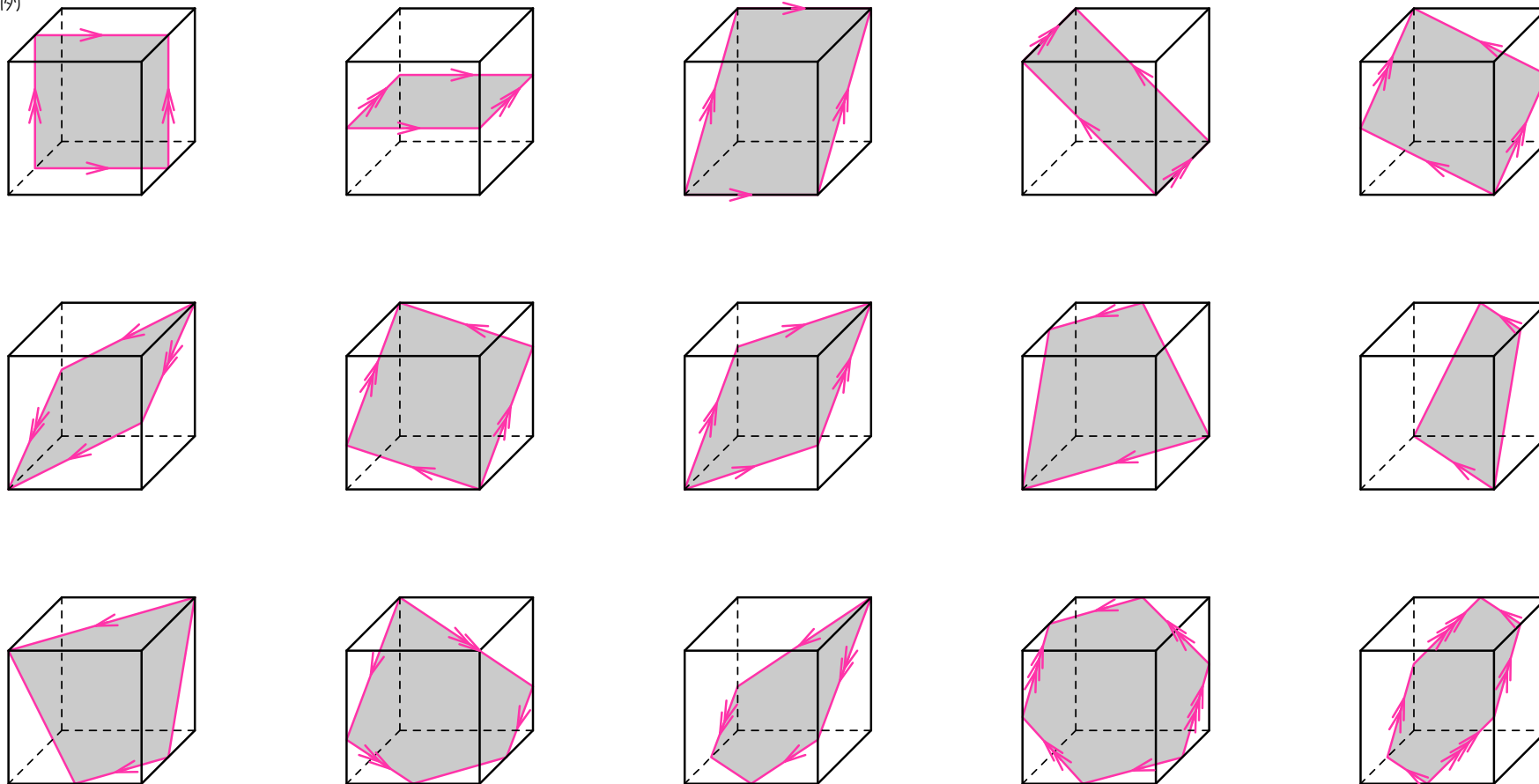

3

(1) 12 (2) 6 (3) 4 (4) 10 (5) 10 (6) 14 (7) 3 (8) 10 (9) 4 (10) 5

4

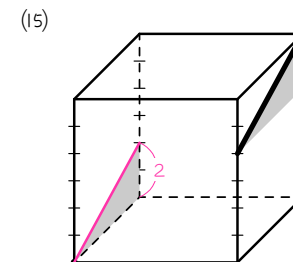
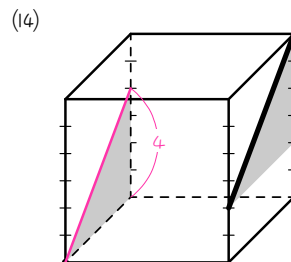
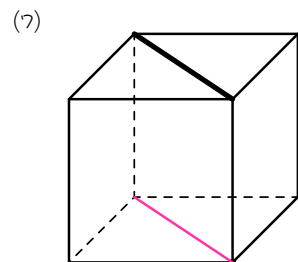
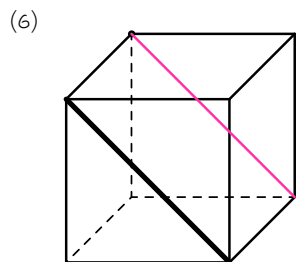
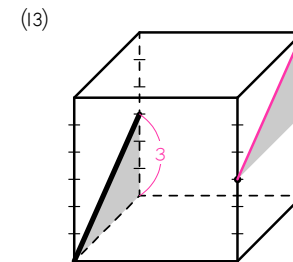
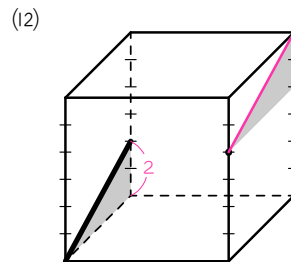
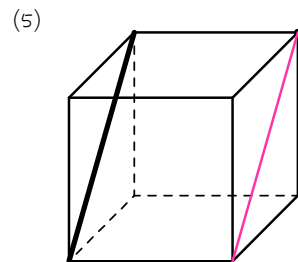
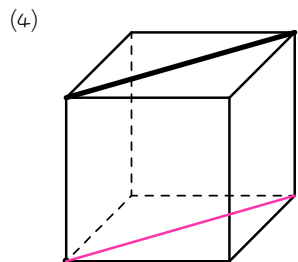
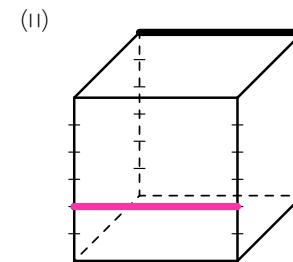
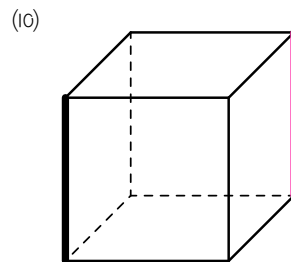
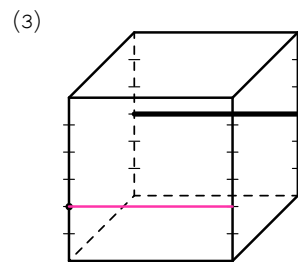
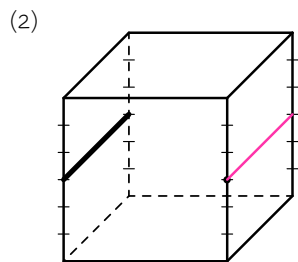
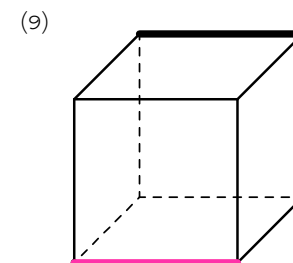
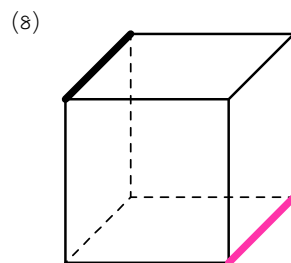
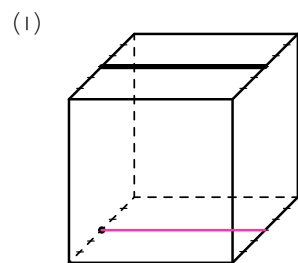

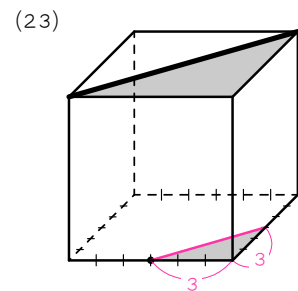
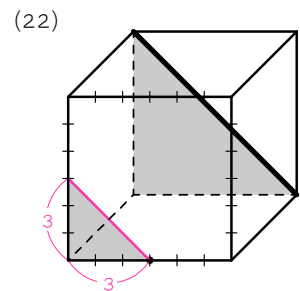
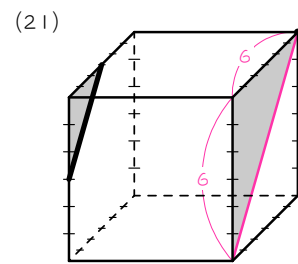
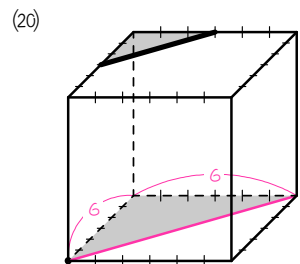
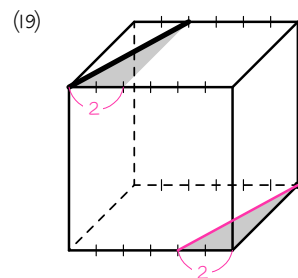
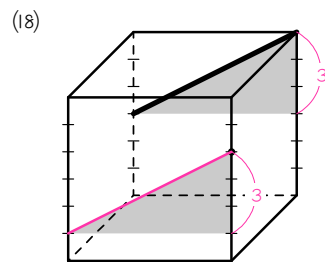
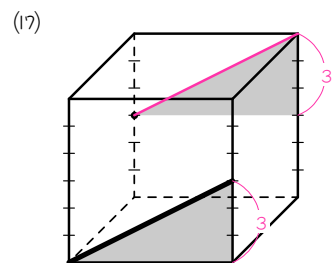
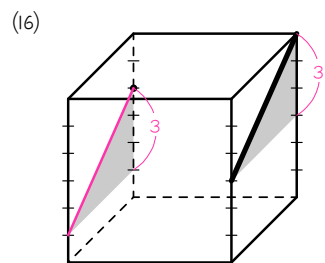

5

